

CDW-13B Noise Sensor

Hunan Coda Electronic Tech Co.,Ltd

T:+86-0731-85117089

W:www.codasensor.com

Noise sensor is a kind of digital and modular multi-function sound level meter.Using a digital signal processing chip and digital detection technology, has a high reliability, good stability, wide dynamic range, without range switching, etc.Can be widely applied to various machines, vehicles, ships, electrical appliances and other industrial noise measurement, can also be used for environmental noise measurement, labor protection, industrial hygiene.

FEATURES

- High Sensitivity
- Fast response
- Low consumption
- Excellent stability
- Long service life
- Easy Installation

Parts

- 1.Noise sensor: 1
- 2.Cable: 1

SPECIFICATIONS

Item	Technical Specification
Range	30-130dB
Accuracy	±3dB@23±5°C,accordance with IEC 61672 standard type 2, calibrated at 94dB(1kHz) input
Frequency response	31.5Hz - 8kHz.
Corrector	B&K 4226
Microphone	Capacitive microphone , size: 0.5 inch
Supply	Mark on the label
Output	RS485,RS232
Power Consumption	<20mW@12VDC
Response Time	<200ms
Operating Temperature	-10°C-+50°C@5-80%RH
Storage	-40-70°C@20%-90%RH
Shell Material	Aluminum alloy or 304SS

3

Dimension

Unit: mm

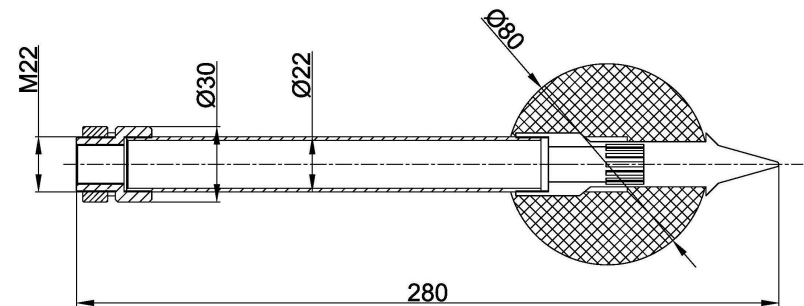

2

4

ELECTRICAL CONNECTIONS

Connector(cable)	RS232/RS485
Red	V+
Yellow	TXD/RS485A
Black	V-
Blue	RXD/RS485B

Note: This product has been tested and complies with European CE requirements for EMC directive.

WARRANTY

This product is warranted to be free of defects in materials and construction for a period of 12 months from date of lead time.

Liability is limited to repair or replacement of defective item.

Communication Protocol (MODBUS)

Transmission mode: MODBUS-RTU, Baud rate: 9600bps, Data bits:8, Stop bit:1, Check bit:no

Slave address:the factory default is 01H (set according to the need,00H to FFH)

- The 03H Function Code Example: Read The Noise value

Host Scan Order(slave address:0x01)

01 03 00 00 00 01 840A

Slave Response

01 03 02 02 55 791B

Noise:(0255)H= (597)D, 597/10=59.7dB

- The 10H Function Code Example: Modify the slave address

Host Scan Order (Changed to 01H, read and write address must be 00H):

00 10 01 BDC0

Slave Response:

00 10 007C

- The 20H Function Code Example: Read the Slave Address (fixed command, ensure that no other devices on the bus)

Host Scan Order:

00 20 00 68

Slave Response(addr.=01H):

00 20 01 A9C0

Note:

1. All underlined is fixed bit;
2. The last two bytes is CRC check command.

5

7

PARAMETER SELECTION TABLE

Remark	Series	Type	Supply	Output	Cable Length	
CD						
	W					
		13B				
			A			5V
			B			12-24V
			X			Other
				A		RS485(MODBUS-RTU)
				B		RS232(MODBUS-RTU)
				X		Other
					2000	Units:mm (typ)
					3000	Units:mm
					...	Units:mm

Example: CDW-13BBA2000 Supply:12-24V, Output:RS485, Cable Length:2m.

6



Complies with applicable CE directives.

Manual subject to change without notice. Version 1.0

Copyright © 2015 Hunan Coda Electronic Tech Co.,Ltd

8